

TURRET MILLING MACHINE HM-54GV

Order Code: (K8744D)

Edition : 1.0
Date: (05/24)

The following section covers the spare parts diagrams and lists that were current at the time this manual was originally printed. Due to continuous improvements of the machine, changes may be made at anytime without notification.

HOW TO ORDER SPARE PARTS

1. Have your machines model number, serial number & date of manufacture on hand, these can be found on the specification plate mounted on the machine
2. A scanned copy of your parts list/diagram with required spare part/s identified.

NOTE: SOME PARTS MAY ONLY BE AVAILABLE AS AN ASSEMBLY

3. Go to www.machineryhouse.com.au/contactus and fill out the inquiry form attaching a copy of scanned parts list.



WARNING!

*Electricity is dangerous and could cause death
All electrical work must be carried out by a qualified electrician.*



CAUTION

It is impossible to cover all possible hazards Every workshop enviroment is different. These are designed as a guide to be used to compliment training and as a reminder to users prior to equipment use. Always consider safety first, as it applies to the individual working conditions.

A: COLUMN PARTS HM-54GV

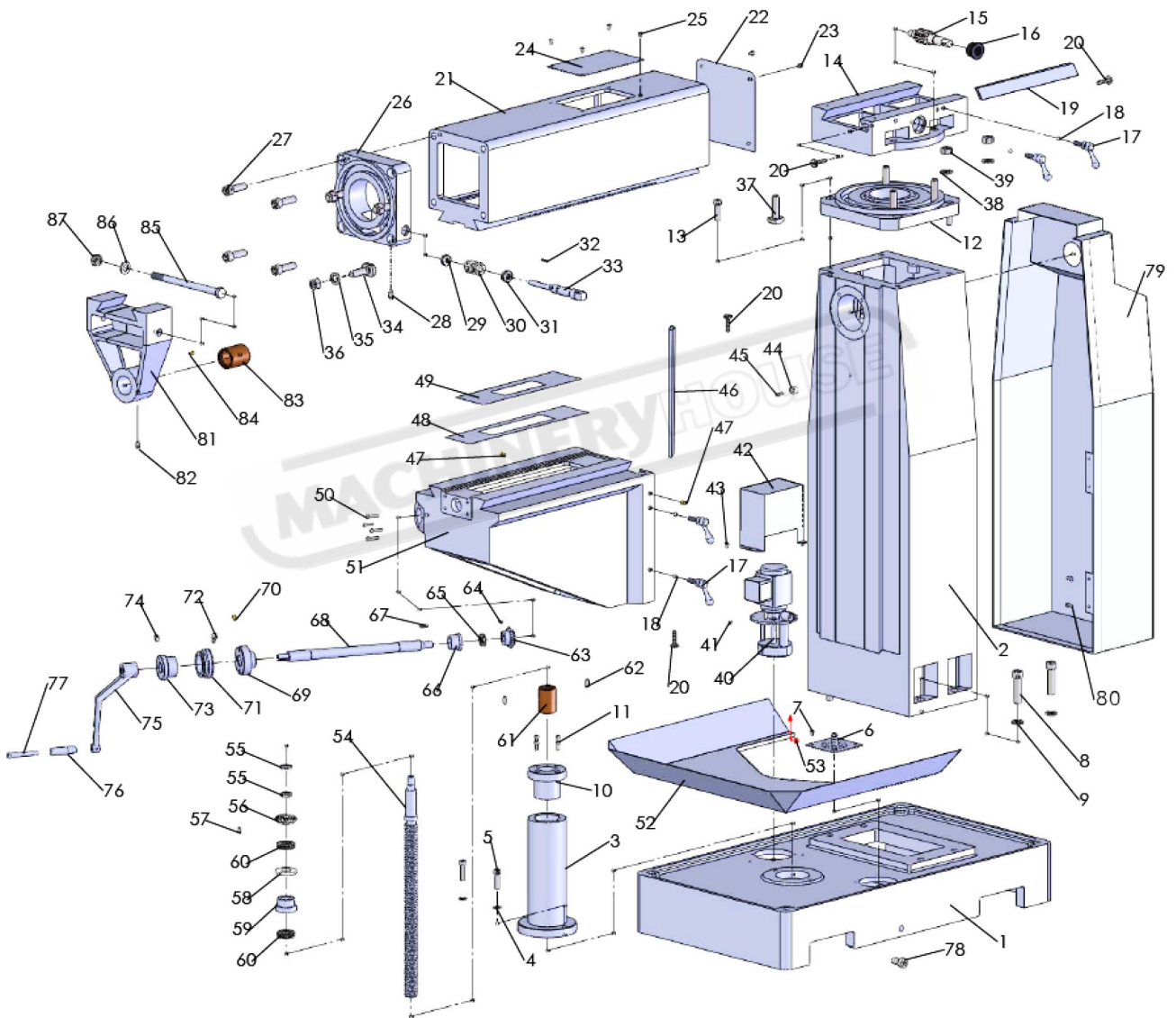

A: COLUMN PARTS LIST HM-54GV

No.	Description	Qty.	No.	Description	Qty.
1	BASE	1	45	SCREW M6x18	1
2	COLUMN	1	46	GIB	1
3	ELEVATING SCREW HOUSING	1	47	BILLIARD OIL CUP	4
4	LOCK WASHER 10MM	2	48	WIPER PLATE	1
5	HEX BOLT M10-1.5x45	2	49	WIPER PLATE	1
6	CONNECT TUBE	1	50	CAP SCREW M6X25	4
7	PHLP HD SCR M6x12	4	51	KNEE	1
8	HEX BOLT M16-2x65	4	52	OIL PAN	1
9	LOCK WASHER 16MM	4	53	CAP SCREW M6X12	2
10	COLLAR	1	54	HOIST DESCEND LEAD SCREW	1
11	CAP SCREW M8-1.25x25	2	55	CIRCULAR NUT M16X1.5	2
12	HOLD SUPPORT	1	56	CONICAL GEAR	1
13	CAP SCREW M12-1.75x30	4	57	KEY 6x6x12	1
14	AROUND BRACKET	1	58	ADJUST WASHER	1
15	FEED SHAFT	1	59	COLLAR	1
16	COLLAR	1	60	BALL BEARING 51105	2
17	CLAMP BOLT M10-1.5x53x25	4	61	NUT 42x60MM	1
18	CLAMP BLOCK	4	62	SET SCREW M8X20	2
19	GIB	1	63	CONICAL GEAR	1
20	FLAT HD SCR M8-1.25x40	4	64	SET SCREW M6-1x10	1
21	OVERARM	1	65	BALL BEARING 51103	1
22	COVER	1	66	COLLAR	1
23	PHLP HD SCR M6-.1x10	4	67	KEY 5x5x20	1
24	COVER	1	68	SHAFT	1
25	PHLP HD SCR M6-.1x10	4	69	COLLAR	1
26	HOLD BRACKET	1	70	CAP SCREW M6-1x22	1
27	CAP SCREW M16-2x50	4	71	SCALE RING	1
28	CAP SCREW M8x20	1	72	KNURLED THUMB SCR M6-1x10	1
29	BALL BEARING 51101	1	73	COLLAR	1
30	WORM	1	74	SET SCREW	1
31	BALL BEARING 51102	1	75	HANDLE	1
32	KEY 4x 4x20	1	76	TAPER KNOB	1
33	WORM SHAFT	1	77	HANDLE SPINDLE	1
34	T BOLT M16-2x60	3	78	SCREW	1
35	WASHER 16MM	3	79	BEHIND COVER	1
36	HEX NUT M16-2	3	80	FLAT HD SCR M5x12	4
37	T BOLT M16-2x50	4	81	SUPPORT	1
38	WASHER 16mm	4	82	SET SCREW M8-1.25x16	1
39	HEX NUT M16-2	4	83	SLEEVE	1
40	ELECTRIC PUMP	1	84	BILLIARD OIL CUP	1
41	CAP SCREW M5X12	4	85	SPECIAL BOLT M16-2x218	1
42	SHIELD	1	86	FLAT WASHER 16MM	1
43	CAP SCREW M5X12	2	87	HEX NUT M16-2	1
44	SLEEVE	1			

NOTE: SOME INDIVIDUAL PARTS MAY ONLY BE AVAILABLE AS AN ASSEMBLY

B: SWIVEL TABLE PARTS HM-54GV

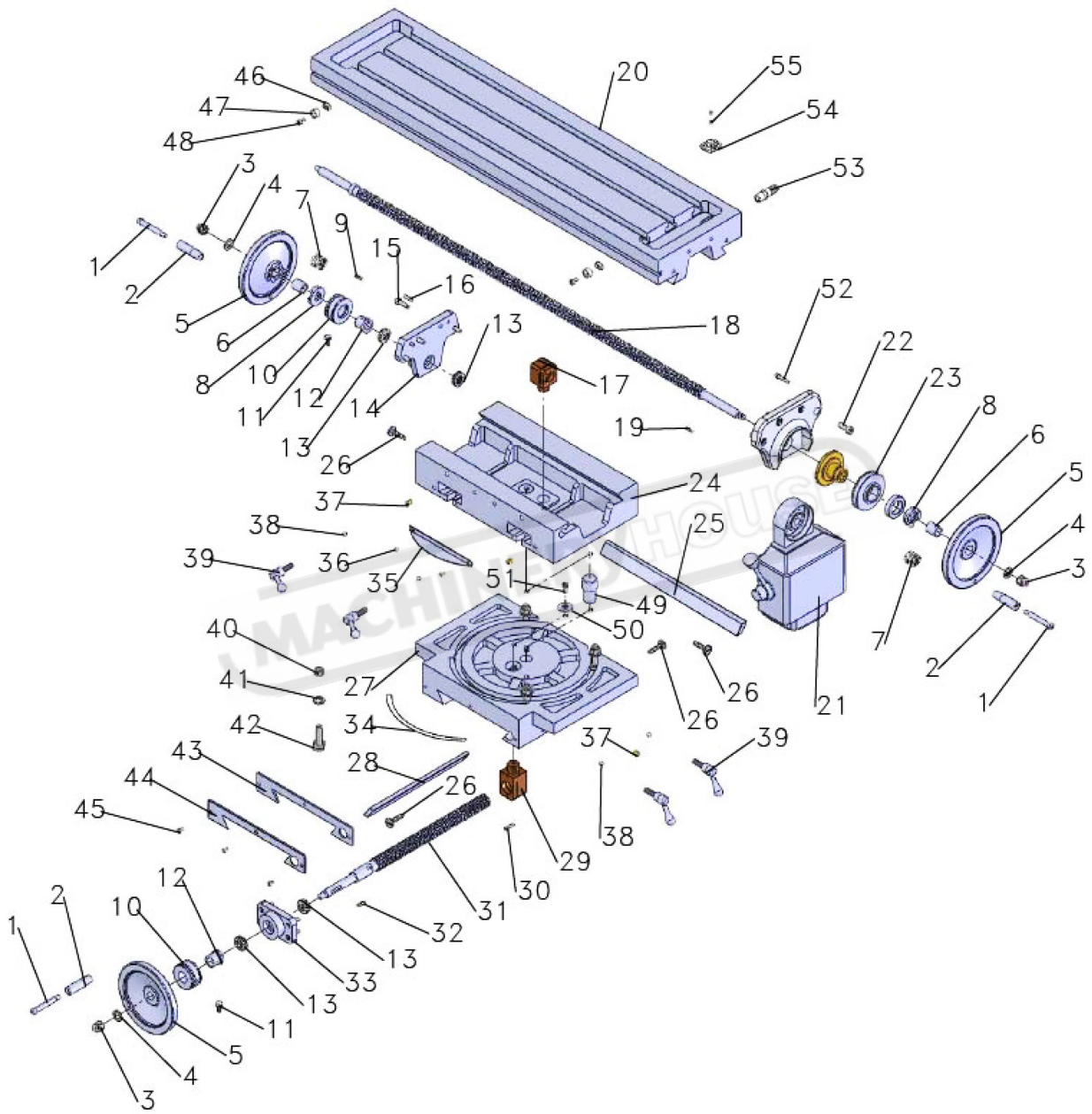

B: SWIVEL TABLE PARTS LIST HM-54GV

No.	Description	Qty.	No.	Description	Qty.
1	HANDLE SPINDLE	3	29	SPECIAL NUT	1
2	TAPER KNOB	3	30	SCREW M5x25	3
3	HEX NUT M12-1.75	3	31	LONG LEAD SCREW	1
4	LOCK WASHER 12MM	3	32	KEY 5x30	1
5	HAND WHEEL	3	33	SUPPORT	1
6	BUSH	2	34	ANGLE RULER	1
7	SPRING	2	35	GUARD	1
8	CONNECT	2	36	SCREW M5X10	2
9	KEY 5x20mm	1	37	OIL CUP 8	4
10	SCALE RING	2	38	CLAMP BLOCK	4
11	CAP SCREW M6-1x16	2	39	CLAMP BOLT M10-1.5x53x25	4
12	COLLAR	2	40	HEX NUT M12	4
13	BALL BEARING 51103	4	41	WASHER M12	4
14	SUPPORT	1	42	T BOLT M12X1.75X42	4
15	CAP SCREW M8x25	6	43	WIPER PLATE	1
16	PIN 6x25mm	2	44	WAY COVER	1
17	SPECIAL NUT	1	45	PHLP HD SCR M5-.8x12	3
18	LONG LEAD SCREW	1	46	SCREW BRACKET	1
19	KEY 5X20mm	1	47	DOG	1
20	TABLE	1	48	CAP SCREW M6-1x16	1
21	POWER FEED	1	49	SHAFT	1
22	CAP SCREW M10x25mm	4	50	WASHER	1
23	SCALE RING	1	51	SCREW M6X30	1
24	ROTARY BRACKET	1	52	PIN 6x25	2
25	GIB	1	53	CONNECT TUBE	1
26	ADJUST SCREW M8-1.25mm	3	54	SPLASH GUARD	1
27	CENTER BASE	1	55	SCREW M4X8	2
28	GIB	1			

NOTE: SOME INDIVIDUAL PARTS MAY ONLY BE AVAILABLE AS AN ASSEMBLY

C: HORIZONTAL SPINDLE PARTS HM-54GV

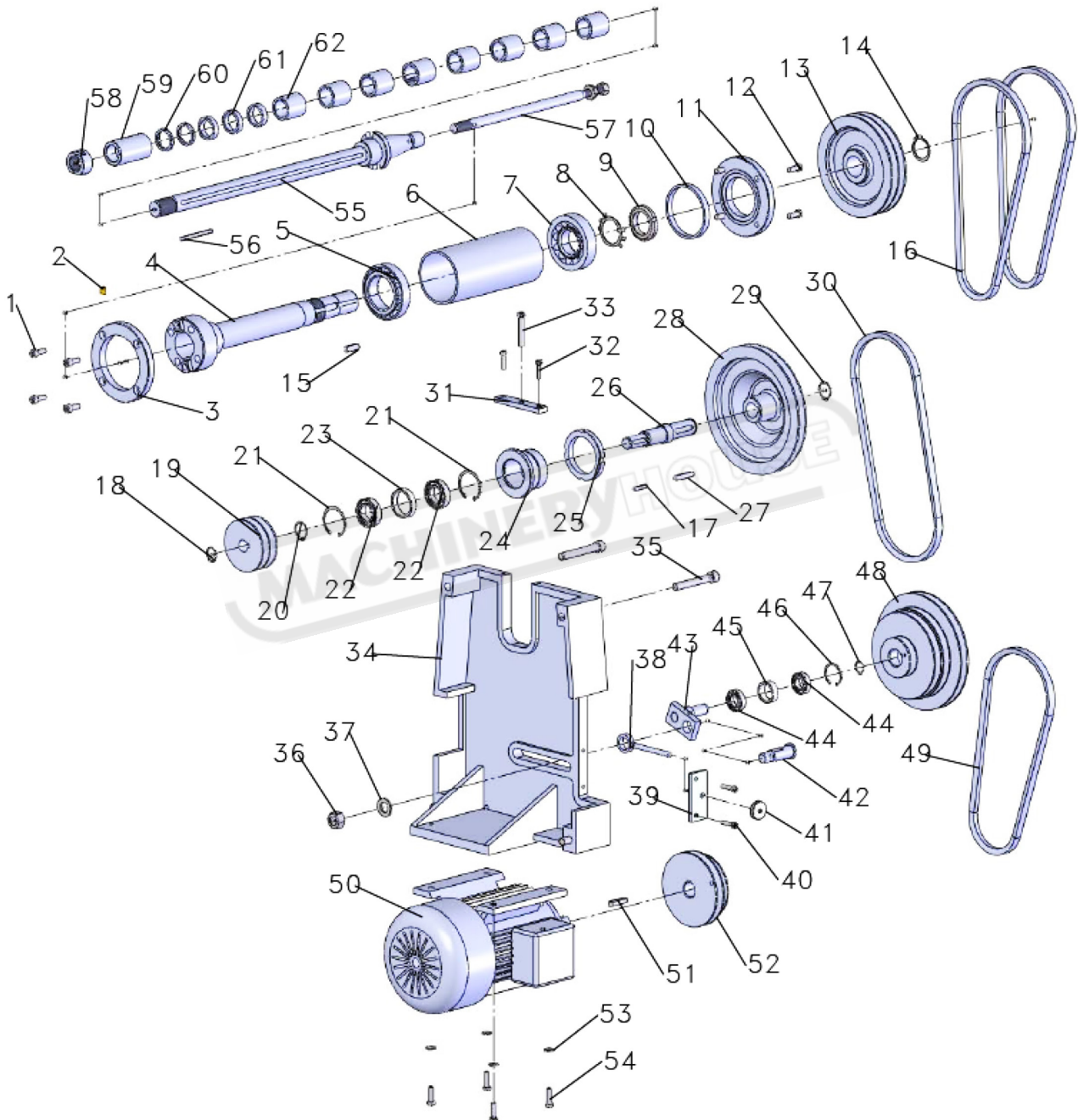

C: HORIZONTAL SPINDLE PARTS LIST HM-54GV

No.	Description	Qty.	No.	Description	Qty.
1	CAP SCREW M8-1.25x25	4	40	CAP SCREW M6-1x25	2
2	OIL CUP	1	41	SPECIAL NUT M8-1.25	1
3	COVER	1	42	SMALL SHAFT	1
4	SPINDLE	1	43	CONNECT	1
5	BALL BEARING 32011	1	44	BALL BEARING 6003	2
6	COLLAR	1	45	COLLAR	1
7	BALL BEARING 30308	1	46	INT RETAINING RING 35MM	1
8	FLAT WASHER 39MM	1	47	EXT RETAINING RING 17MM	1
9	SLOTTED LOCK NUT M39X1.5	1	48	PULLEY	1
10	SPECIAL WASHER 90x4	1	49	V-BELT A800	1
11	COVER	1	50	MOTOR	1
12	CAP SCREW M8-1.25x25	4	51	KEY 8X45	1
13	SPINDLE PULLEY	1	52	MOTOR WHEEL	1
14	RETAINING RING	1	53	LOCK WASHER 8MM	4
15	KEY 10X8X30	1	54	HEX BOLT M8-1.25x30	4
16	V-BELT A838	2	55	HORIZONTAL ARBOR	1
17	KEY 6X30	1	56	KEY	1
18	EXT RETAINING RING 20	1	57	HORIZONTAL ARBOR	1
19	WHEEL	1	58	ARBOR NUT	1
20	EXT RETAINING RING 25	1	59	ARBOR SLEEVE	1
21	INT RETAINING RING 47MM	2	60	ARBOR SPACER	2
22	BALL BEARING 6005	2	61	COLLAR	3
23	COLLAR	1	62	ARBOR SLEEVE	8
24	COLLAR	1			
25	SPECIAL NUT M64X2	1			
26	SMALL SHAFT	1			
27	KEY 8X40	1			
28	PULLEY	1			
29	EXT RETAINING RING 25MM	1			
30	V-BELT A864	1			
31	SUPPORT	1			
32	CAP SCREW M6-1x25	2			
33	HEX BOLT M8-1.25x60	1			
34	MOTOR BASE	1			
35	CAP SCREW M12-1.75x85	4			
36	HEX NUT M16-2	1			
37	FLAT WASHER 16MM	1			
38	ADJUST SCREW M8-1.25	1			
39	SUPPORT	1			

NOTE: SOME INDIVIDUAL PARTS MAY ONLY BE AVAILABLE AS AN ASSEMBLY

D: SPINDLE BOX PARTS HM-54GV

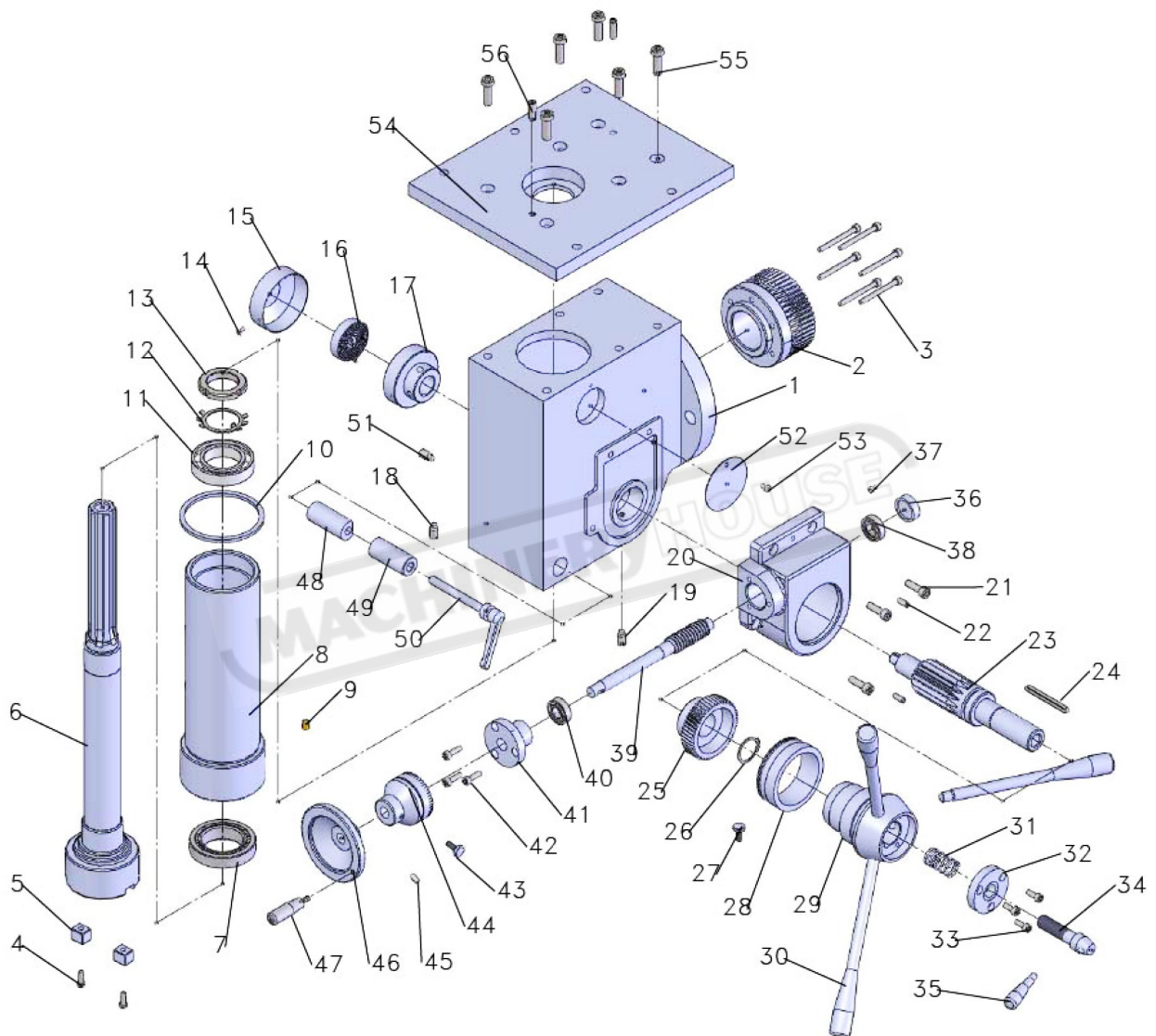

D: SPINDLE BOX PARTS LIST HM-54GV

No.	Description	Qty.	No.	Description	Qty.
1	SPINDLE BOX	1	40	BALL BEARING 6002	1
2	GEAR	1	41	COVER	1
3	SCREW M6X75	6	42	SCREW M6-1x20	3
4	SCREW M6X16	2	43	CAP SCREW M6-1x16	1
5	FIXED KEY	2	44	SCALE RING	1
6	SPINDLE	1	45	SCREW M6-1x12	1
7	BALL BEARING 32010	1	46	HANDLE WHEEL	1
8	SLEEVE	1	47	HANDLE	1
9	OIL CUP	1	48	CLAMP BLOCK	1
10	RUBBER WASHER 90MM	1	49	CLAMP BLOCK	1
11	BALL BEARING 6009	1	50	CLAMP HANDLE	1
12	LOCK WASHER 40	1	51	SET SCREW M10X10	2
13	LOCK NUT M40X1.5	1	52	BAFFLE	1
14	CAP SCREW M4X8	1	53	SCREW M5X10	1
15	SPRING CAP	1	54	HEAD BOX COVER	1
16	SPRING PLATE	1	55	SCREW M10X30	6
17	SPRING BASE	1	56	PIN 8X25	2
18	SET SCREW M8X16	1			
19	SET SCREW M8X16	1			
20	HANDL WHEEL GEAR BOX	1			
21	SCREW M8X25	3			
22	PIN 6X25	2			
23	FEED SHAFT	1			
24	KEY 8X38	1			
25	HELICAL GEAR	1			
26	EXT RETAINING RING 30	1			
27	CAP SCREW M6-1x16	1			
28	SCALE RING	1			
29	HANDLE BRACKET HUB	1			
30	HANDLE BAR	2			
31	COMPRESSION SPRING	1			
32	COVER	1			
33	CAP SCREW M6X16	3			
34	HANDLE SEATM16X2	1			
35	HANDLE BAR	1			
36	COVER	1			
37	SCREW M6X12	1			
38	BALL BEARING 6002	1			
39	WORM	1			

NOTE: SOME INDIVIDUAL PARTS MAY ONLY BE AVAILABLE AS AN ASSEMBLY

E: GEAR HEAD PARTS HM-54GV

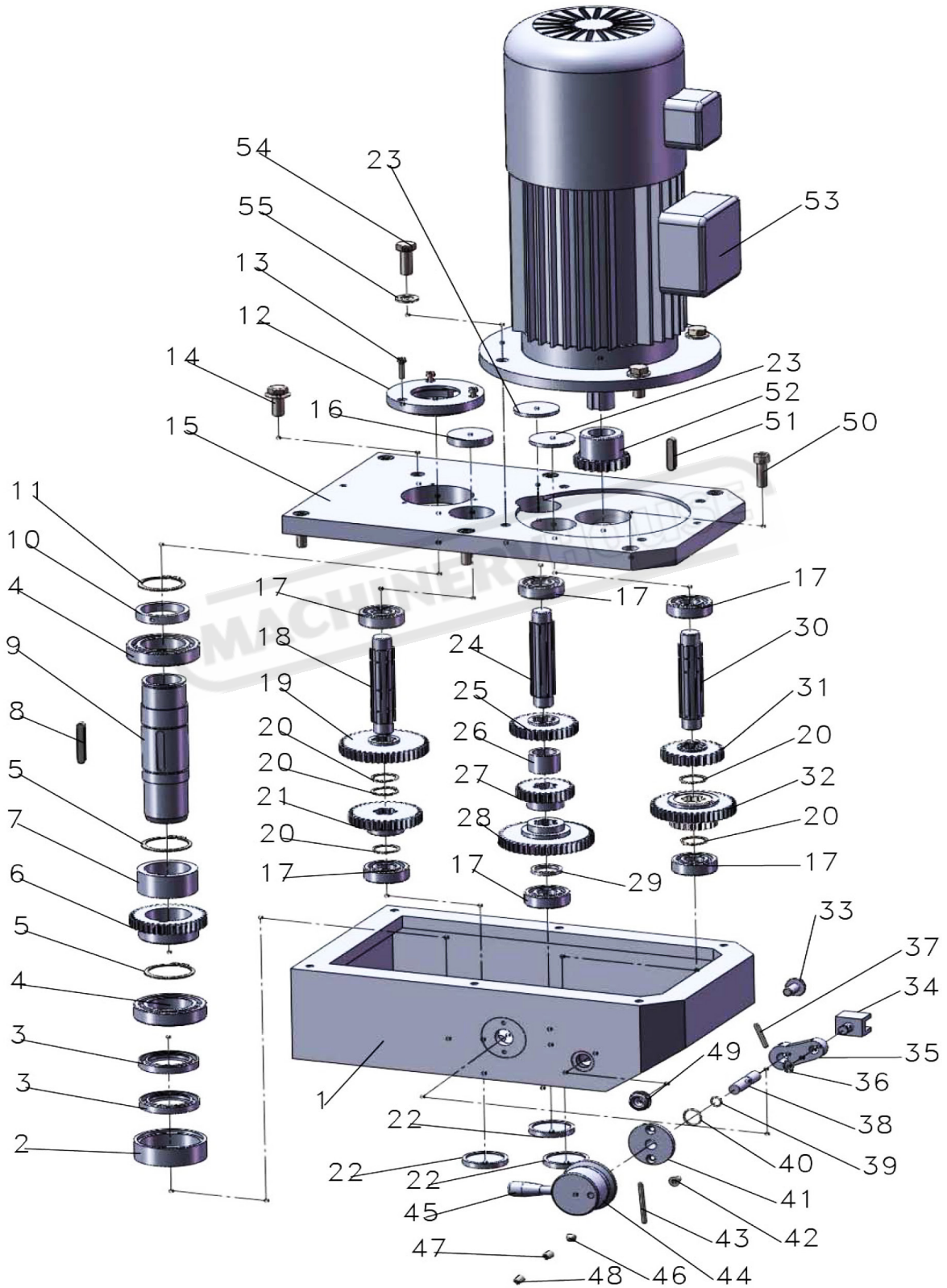

E: GEAR HEAD PARTS LIST HM-54GV

No.	Description	Qty.	No.	Description	Qty.
1	GEAR CASE	1	40	RUBBER RING 20X2	1
2	COLLAR	1	41	COVER	1
3	OIL SEAL FB45X62X8	2	42	SCREW 5X12	2
4	BALL BEARING 6009	2	43	PIN 5X50	1
5	EXT RETAINING RING 45	2	44	HANDLE SEAT	1
6	GEAR	1	45	HANDLE	1
7	COLLAR	1	46	STEEL BALL 6	1
8	KEY 8X50	1	47	SPRING	1
9	SHAFT	1	48	SET SCREW	1
10	SPEED MEASUREMENT	1	49	OIL POINTER	1
11	EX RETAINING RING 45	1	50	CAP HEAD SCREW	6
12	COLLAR	1	51	KEY 8X40	1
13	SCREW M5X15	3	52	GEAR	1
14	HEX BOLT M16X1.5	1	53	MOTOR	1
15	BOX COVER	1	54	SCREW M12X30	4
16	COVER	1	55	WASHER 12	4
17	BALL BEARING 6204	6			
18	DRIVING SHAFT	1			
19	GEAR	1			
20	EX RETAINING RING 25	5			
21	GEAR	1			
22	COVER	3			
23	COVER	2			
24	DRIVING SHAFT	1			
25	GEAR	1			
26	COLLAR	1			
27	GEAR	1			
28	GEAR	1			
29	RING	1			
30	DRIVING SHAFT	1			
31	GEAR	1			
32	GEAR	1			
33	HEX BOLT M10X1	1			
34	LIFT FORK	1			
35	ROCKER ARM	1			
36	EX RETAINING RING 10	1			
37	PIN 5X30	1			
38	SMALL SPINDLE	1			
39	RUBBER RING 12X2	1			

NOTE: SOME INDIVIDUAL PARTS MAY ONLY BE AVAILABLE AS AN ASSEMBLY

D: Electrical diagram hm-54Gb

